

Infrared Camera

# VELOX 81k SM

with Indium Antimonide (InSb) Image Sensor

320 x 256 Pixels  
1.5  $\mu\text{m}$  – 5.5  $\mu\text{m}$   
384 Hz



State-of-the-art IR image sensor



Numerous optional features



Several data interface options

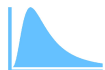

Radiometric calibration



Scientific, industrial and OEM software solutions



Broad selection of lenses



Customization of hardware and software

## Specifications

<b>Spectral range</b>	1.5 $\mu\text{m}$ – 5.5 $\mu\text{m}$
<b>Detector technology</b>	Indium Antimonide (InSb)
<b>Format</b>	81 920 (320 x 256) Pixels
<b>Sensor size</b>	9.60 mm x 7.68 mm
<b>Pixel pitch</b>	30 $\mu\text{m}$
<b>Aperture</b>	F/3
<b>NETD</b>	< 20 mK
<b>Fullframe rate</b>	384 Hz
<b>Integration time</b>	Adjustable
<b>Operating mode</b>	Snapshot (integrate-while-read)
<b>A/D Resolution</b>	14 bit
<b>Dimensions (mm)</b>	L=220, W=120, H=141
<b>Weight</b>	4 kg
<b>Data interface</b>	Camera Link (additional/alternative interfaces optional)
<b>Input voltage</b>	24 V
<b>Power</b>	< 40 W
<b>Cooler</b>	Stirling (Rotary)
<b>Working temperature</b>	-15 °C to 50 °C
<b>Storage temperature</b>	-40 °C to 70 °C

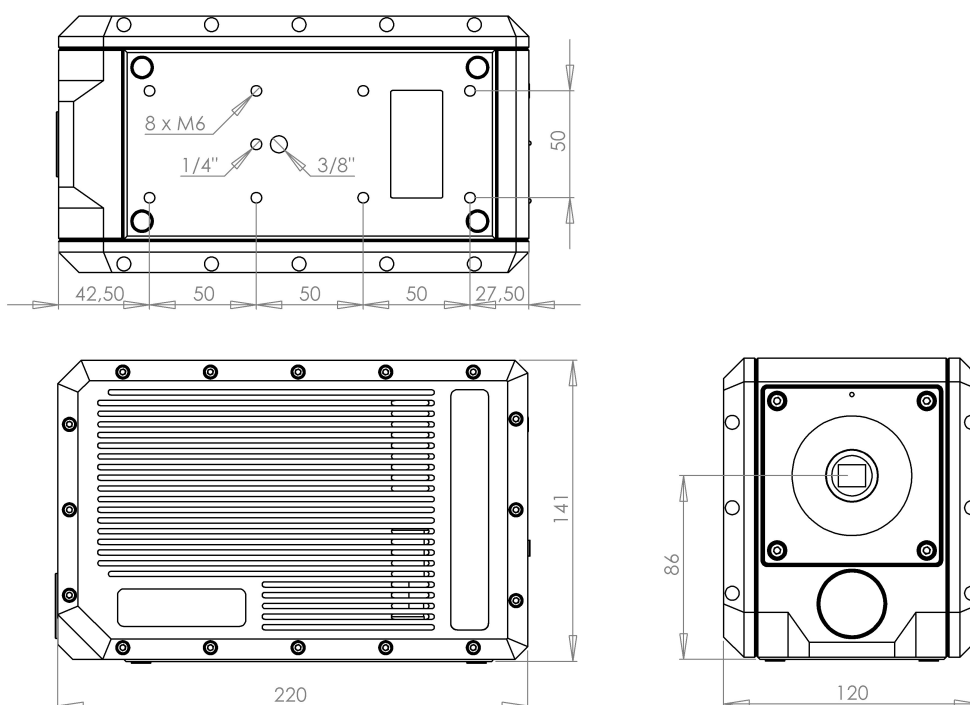

## Main Features

<b>Focal Plane Array (FPA) Sensor</b>	The camera uses a cryogenically cooled FPA quantum detector which counts incoming photons during the integration time. By using a global shutter, all pixels are sensitive during the same period of time. The FPA is mounted in an evacuated Dewar and is located behind a cooled radiation shield ("cold stop").
<b>Stirling Cooler</b>	Coolers with different MTTF are available. In case of failure, IRCAM can replace the cooler in-house within a few working days.
<b>Data Interface Camera Link</b>	Camera Link is a well-established, stable and reliable interface between camera and computer (via framegrabber card). In "Medium" configuration, the interface uses two cables. Fiber-optic cables can be used to increase transmission length. Additional secondary data interfaces can be integrated (see "Options" next page).
<b>Windowing Mode</b>	In windowing mode, only a rectangular part of the image sensor is read out. Decreasing the vertical size results in a higher maximum frame rate.
<b>Multiple Integration Time Mode</b>	The camera can change the integration time from frame to frame. Up to 6 integration times can be pre-selected. The mode can be used to increase the camera's dynamic range.
<b>Image Meta Data</b>	Every frame transmitted from the camera contains a lot of additional information which belongs to the image, like e.g. frame number, MIO signal status, operating hours, etc.
<b>Custom Backpanel</b>	Based on a modular concept, the camera backpanel is customized to support all available features and electrical interfaces of the camera.
<b>Ventilation System</b>	An active cooling system with integrated fans maintains the thermal drift on a low level, which is important for the measurement accuracy and permits to use the camera at elevated ambient temperatures.
<b>Smart Lens Interface</b>	Lenses are mounted with a square flange. The flange contains integrated electronics for storage of the lens ID and measurement of the lens temperature. Camera and software automatically recognize the lens and use the temperature information for thermal compensation. The lens is thermally isolated from the camera housing.



## Options (Interfaces & Features) Selection

<b>Data Interface GigE</b>	Connects to any PC via network interface card. Note: max. frame rate limited by bandwidth to approx. 45 Hz
<b>Data Interface USB 3.0</b>	Connects to any PC via USB 3.0. Optional: fiber-optic extension for long-distance transmission.
<b>Data Interface 10-GigE</b>	Connects to any PC via 10-GigE (fiber-optic transmission) For laptops: with Thunderbolt 3 adapter.
<b>Data Interface CoaXPress</b>	Alternative to Camera Link. Requires CoaXPress framegrabber.
<b>MIO Measurement Interface</b>	MIO D: 2 digital inputs, 2 digital outputs, MIO DA: plus 2 analog inputs
<b>IRIG-B Input</b>	For time signal from external digital IRIG-B signal source Optional: Adapter with analog input
<b>GNSS/GPS Input</b>	Built-in GNSS receiver. Requires external antenna (via SMA connector).
<b>Dual-Mode Filter Wheel</b>	Switching and synchronized spinning mode. 6 positions for standard filters with 25 mm - 25.4 mm (1 inch) diameter.
<b>Filter Holder</b>	Accepts standard filters with 25 mm - 25.4 mm (1 inch) diameter.
<b>Motor Focus</b>	Integrated into camera housing. Universal for all lenses. Operation by software (e. g. IRCAM Works).
<b>Shutter</b>	Camera-integrated, motorized shutter. Versions: passive, heated, temperature-controlled, NIR
<b>VIS Camera</b>	Integrated camera for visible range. Different versions available. Connected to PC via USB 2.0. C-Mount lens interface.
<b>IP65</b>	Sealing of camera housing, including lens flange. Use of sealed connectors.
<b>Longlife Stirling Cooler</b>	Cooler with MTTF 28.000 h
<b>Embedded PC</b>	Runs IRCAM Works software. Video output via HDMI. USB 2.0 for keyboard, mouse, remote control, storage media
<b>IRCAM Rail</b>	Compatible to NATO Accessory Rail (STANAG 4694), on top of the camera for mounting of handle, monitor, etc.

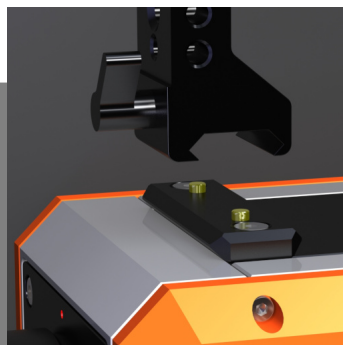

## Software

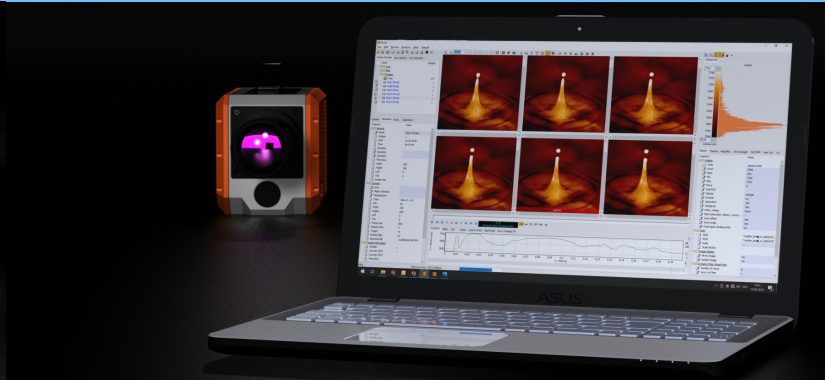
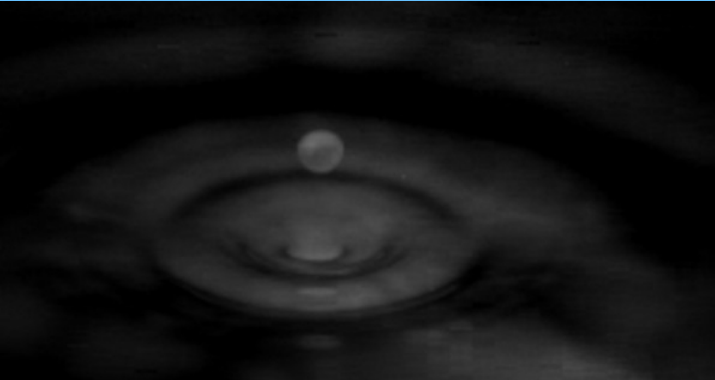

### IRCAM Works

Software for scientific and industrial R&D infrared imaging applications

- Camera control & image acquisition
- Processing and display of images
- Recording and playback of images and videos
- Data export
- Evaluation of data
- Measurement of temperature and radiation

### Script for Works

Extension for IRCAM Works

Script-based automatization & customization of measurements and processing of data

- Script language with over 200 commands (camera control, image acquisition, ...)
- Script editor
- Script examples
- Support & custom development

### Lock-in for Works

Extension for IRCAM Works

Lock-in thermography for non-destructive testing and other applications

- Real-time data processing and display of results
- Calculation of amplitude image, phase image,  $0^\circ$  image,  $-90^\circ$  image
- Control of excitation sources

### IRCAM SDK

Software library for using IRCAM cameras with several programming environments

- IRCAM API (C++, C#, Delphi), 32-bit & 64-bit, LabVIEW Toolkit, MATLAB Interface
- IR camera control, image acquisition and processing, temperature measurement
- Documentation & code examples

## IR Lenses (I)

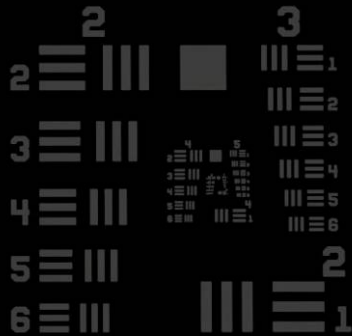

### Standard Lenses

- Optimized for the camera’s image sensor and cold shield
- Chromatic correction for specified spectral range
- High “speed” due to large aperture (F/2 or better)
- Wide working distance range (optional: extension rings & close-up lenses)

Model	Focal length	Spectral range	F#	WD
IR M 10	10 mm	3.0 $\mu\text{m}$ – 5.5 $\mu\text{m}$	2.0	0.1 m – infinity
IR M 15 MP	15 mm	3.0 $\mu\text{m}$ – 5.5 $\mu\text{m}$	1.5	0.1 m – infinity
IR M 25	25 mm	3.0 $\mu\text{m}$ – 5.5 $\mu\text{m}$	2.0	0.1 m – infinity
IR M 50	50 mm	3.0 $\mu\text{m}$ – 5.5 $\mu\text{m}$	2.0	0.3 m – infinity
IR M 100	100 mm	3.0 $\mu\text{m}$ – 5.5 $\mu\text{m}$	2.0	2 m – infinity
IR M 200 MP	200 mm	3.0 $\mu\text{m}$ – 5.5 $\mu\text{m}$	2.0	10 m – infinity
IR SM 29 MP	29 mm	1.5 $\mu\text{m}$ – 5.5 $\mu\text{m}$	1.5	0.1 m – infinity
IR SM 50 MP	50 mm	1.5 $\mu\text{m}$ – 5.5 $\mu\text{m}$	2.0	1 m – infinity
IR SM 100 MP	100 mm	1.5 $\mu\text{m}$ – 5.5 $\mu\text{m}$	2.0	3 m – infinity
IR SM 300	300 mm	1.5 $\mu\text{m}$ – 5.5 $\mu\text{m}$	2.0	10 m – infinity

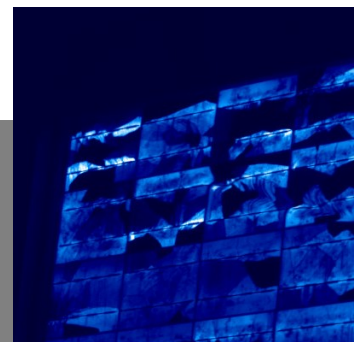
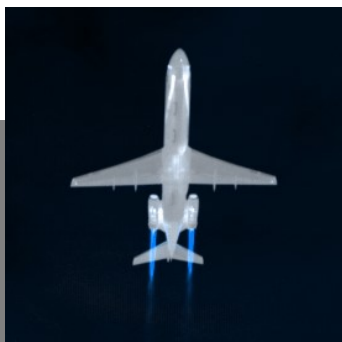

## IR Lenses (2)

### Close-up Lenses

Model	Magnification	Spectral range	F#	WD
IR M CU 35/50 *	2 x	3.0 $\mu\text{m}$ – 5.5 $\mu\text{m}$	N/A	35 mm
IR M CU 100/50 *	0.5 x – 0.7 x	3.0 $\mu\text{m}$ – 5.5 $\mu\text{m}$	N/A	75 mm – 100 mm
IR M CU 250/50 *	0.2 x – 0.4 x	3.0 $\mu\text{m}$ – 5.5 $\mu\text{m}$	N/A	135 mm – 250 mm
IR M CU 500/50 *	0.1 x – 0.3 x	3.0 $\mu\text{m}$ – 5.5 $\mu\text{m}$	N/A	185 mm – 500 mm
IR M CU 500/100 **	0.2 x – 0.4 x	3.0 $\mu\text{m}$ – 5.5 $\mu\text{m}$	N/A	250 mm – 500 mm

\* attaches to IR M 50

\*\* attaches to IR M 100

WD: Working distance

### Microscope Lenses

Model	Magnification	Spectral range	F#	WD
IR M Micro 1x	1 x	3.0 $\mu\text{m}$ – 5.5 $\mu\text{m}$	2.0	14 mm
IR M Micro 2x	2 x	3.0 $\mu\text{m}$ – 5.5 $\mu\text{m}$	2.0	14 mm
IR M Micro 5x	5 x	3.0 $\mu\text{m}$ – 5.5 $\mu\text{m}$	4.0	14 mm
IR M Micro 5x WD35	5 x	3.0 $\mu\text{m}$ – 5.5 $\mu\text{m}$	4.0	35 mm
IR M Micro 10x Mirror	10 x	1.0 $\mu\text{m}$ – 11.0 $\mu\text{m}$		30 mm
IR M Micro SIL	4 x	3.0 $\mu\text{m}$ – 5.5 $\mu\text{m}$	N/A	0 mm

### Custom Lens Design

You have not found the perfect IR lens for your application? Contact us.

IRCAM offers custom optical and mechanical design and manufacturing, from prototype to production.

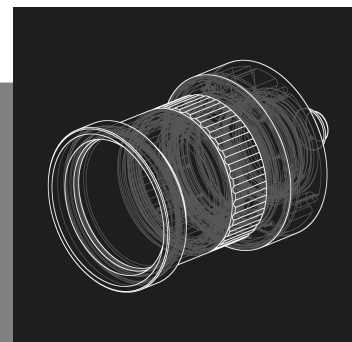
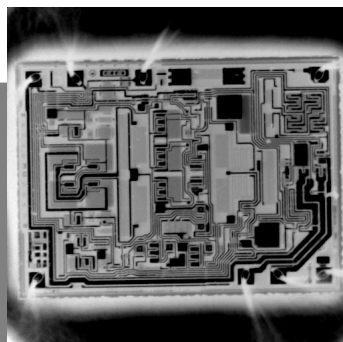

## About IRCAM / Capabilities



Dual-band IR panorama image of the city of Erlangen

### The IR Camera Specialists

IRCAM – established in 2005 – specializes in the design and manufacturing of standard and customized scientific-grade cameras for the infrared spectrum. Our technical team of developers, engineers, scientists and assemblers is passionate about IR imaging technology and implementing state-of-the-art IR quantum detectors. IRCAM cameras are used worldwide for scientific and industrial applications.

### Capabilities & Services

- IR image sensor integration
- Mechanical design and manufacturing
- Electronic design and manufacturing
- Optics design and manufacturing
- Software development
- Radiometric calibration
- Custom development and manufacturing of IR cameras, components and systems
- Application support by scientists
- Technical support by developers

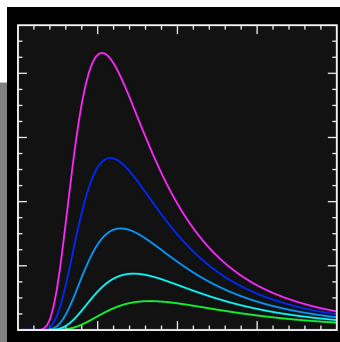
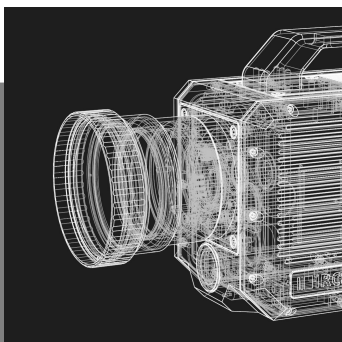

IRCAM GmbH  
Nürnberger Straße 71  
91052 Erlangen  
Germany  
[www.ircam.de](http://www.ircam.de)